

Onyx 90 Media Cutter

Owner's Manual

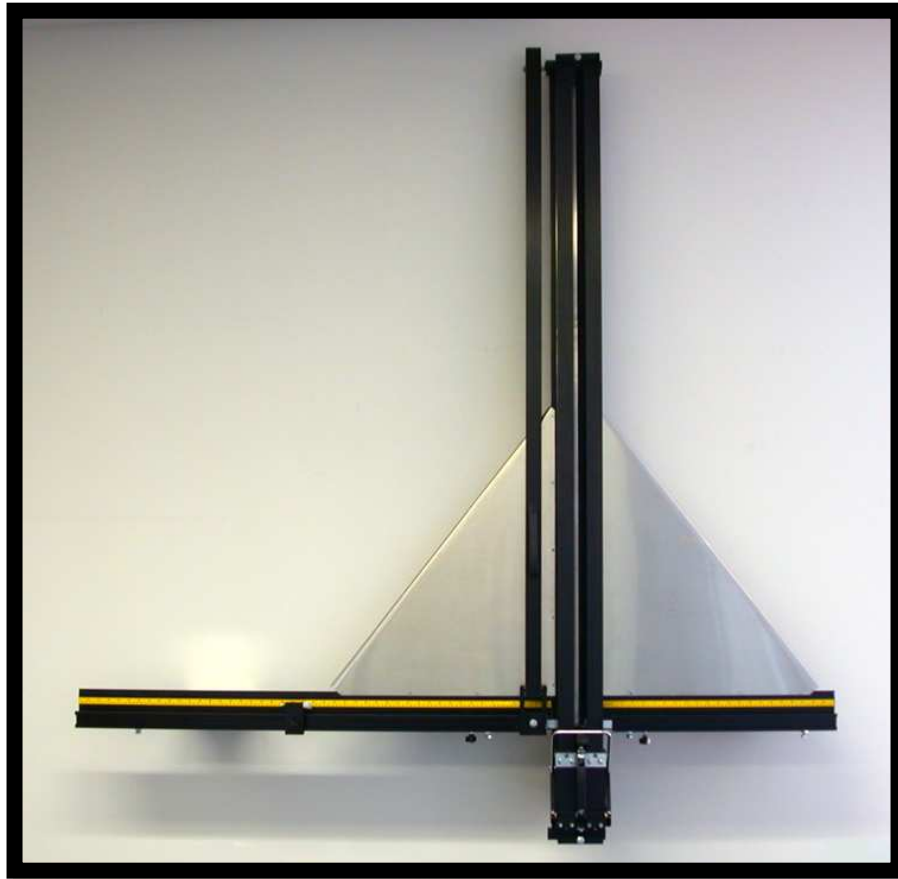

Know Your Onyx 90 Media Cutter

Professional Picture Frame Equipment

1237 Shipp Street

Hendersonville, North Carolina 28791

Vol.213

The World's Best Media Cutter 828-707-5848

Onyx 90 Media Cutter

Congratulations and thank you! You have just purchased what we believe is the best wall mounted media cutter in the world. The Onyx 90 will provide you with a lifetime of dependable service with only minimal maintenance.

We know you are anxious to begin using it. But before you do anything, please take the necessary time to read and understand this manual. It will answer a lot of your questions and avoid possible problems.

Table of Contents

1.0	Safety Precautions & Recommendations	Page 3
2.0	Registration & Warranty	Page 3
3.0	Know Your Machine	Page 3
4.0	Installation of the Onyx 90	Page 5
5.0	Cutting Tool Holders	Page 9
6.0	Using the Onyx 90	Page 10
7.0	Routine Maintenance	Page 13
8.0	Adjustments	Page 13
9.0	Troubleshooting	Page 17

Every Onyx 90 machine is made using computer controlled (CNC) machinery here in North Carolina. Every machine is assembled from the parts made here and assembled on a wall by experienced assembler technicians.

It is adjusted and set up for cutting glass, mat board and acrylic. There is a form that comes with machine showing it was checked and approved by a supervisor.

Please DO NOT ADJUST the machine.

Onyx 90 Media Cutter

1. Safety Precautions & Recommendations

When using the Onyx 90, basic safety precautions should always be followed to eliminate the risk of damage or injury to persons or materials. **Wear safety glasses, gloves and protective clothing.** Use caution when using, transporting, storing or disposing of dangerous objects, such as cutting tools, glass, etc. Make sure the machine is mounted securely. Many situations exist that we can not predict, but it is critical that your Onyx 90 is attached securely and solidly to the wall. Keep the machine and the work area around the machine clean. Never place your hand or fingers behind the media clamp.

For what it is worth – be safe!

2.0 Registration & Warranty

Your Onyx 90 has a 5 year manufacturer's warranty from the date of purchase. Please take a moment to complete and mail the enclosed warranty card. Proof of purchase must be submitted with the warranty card.

Professional Picture Frame Equipment warrants the Onyx 90 to be free from defects in workmanship and parts for 5 years from the date of purchase. Professional Picture Frame Equipment warrants it will repair or replace any defective parts. The Onyx 90 must be subjected to normal use and service. A return merchandise authorization (RMA) must be requested from Professional Picture Frame Equipment before returning. The transportation to and from the factory is the customer's responsibility. This warranty is in lieu of all other agreements. Professional Picture Frame Equipment is not liable for any damages or losses, incidental or consequential, direct or indirect, arising out of the use of this product.

3.0 Know Your Machine

Diagram of Parts

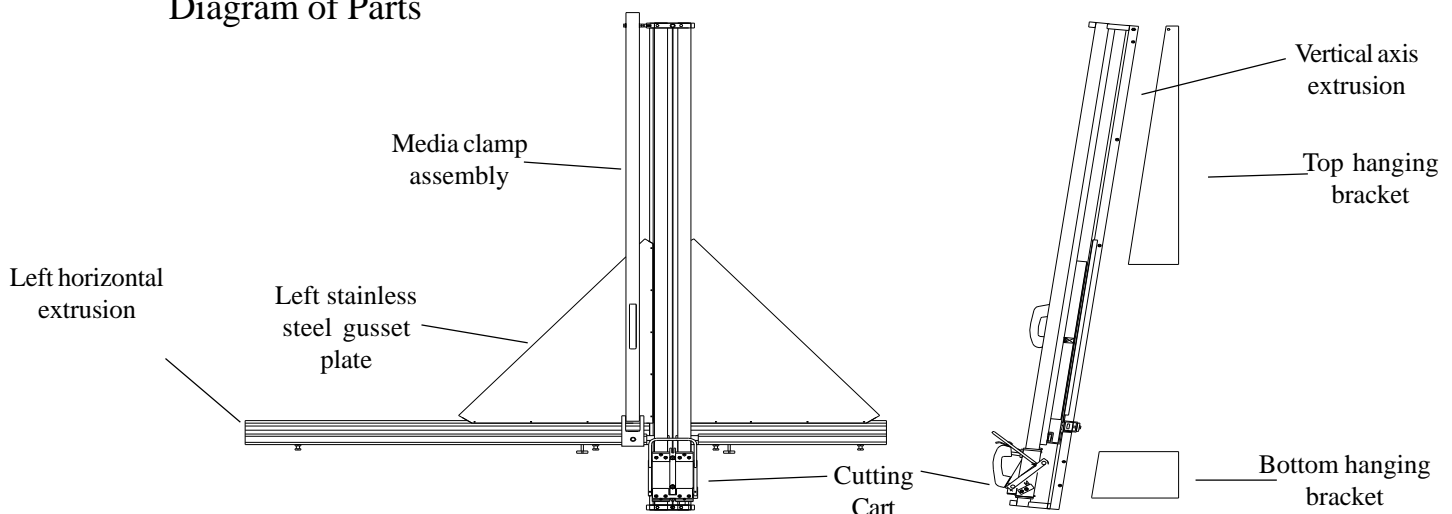

Onyx 90 Media Cutter

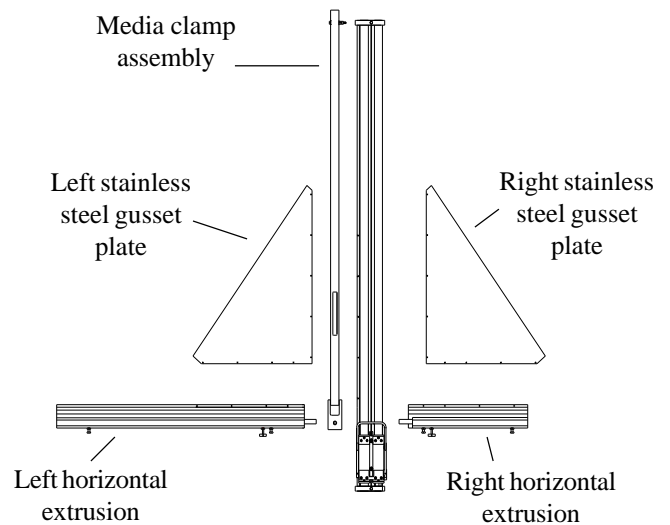
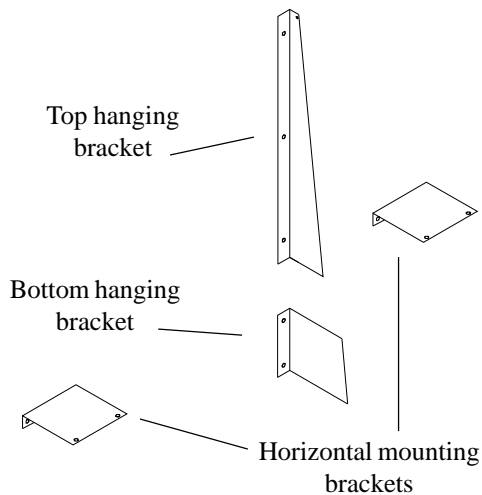

List of Parts That Were Shipped

- Owner's Manual
- Box (large cardboard shipping box)
- Media Clamp Assembly
- Bearing-tubes and Cart Assembly with attached Vertical Axis Extrusion unit
- Left Horizontal Extrusion
- Right Horizontal Extrusion
- Stainless Steel Gusset Plates (2)
- Vertical Wall Mounting Brackets (2)
- Horizontal Wall Mounting Brackets (2)
- Hardware Packets (4)
- Glass Cutting Tool Holder
- Mat Board Cutting Tool Holder
- Plastic Cutting Tool Holder
- Production Stop
- Spare Mat Cutting Blades

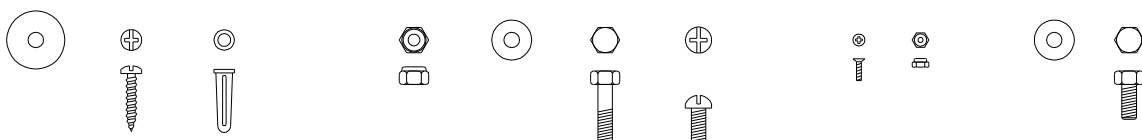
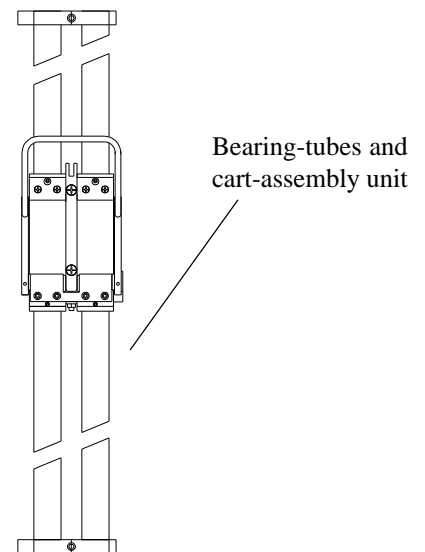

Onyx 90 Media Cutter

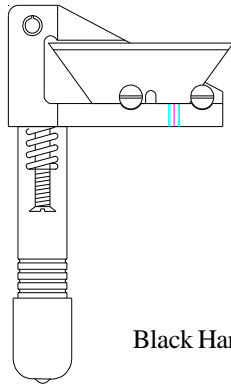

Black Handle

Mat cutting tool

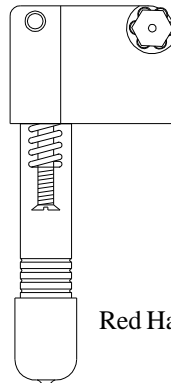

Red Handle

Glass cutting tool

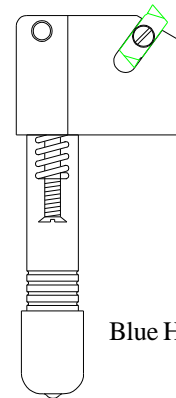

Blue Handle

Acrylic cutting tool

4.0 Installation

Tools you will need to collect before beginning installation

- An assistant
- Ladder
- Level, preferably at least 3 ft long
- Electric drill/screwdriver with either a 1/4" masonry drill bit or 1/8" wood bit
- Hammer
- Phillips head screwdriver, large
- Tape measure
- Straightedge, 36" or longer
- Builder's square
- Pencil

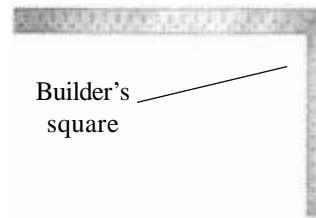

Builder's square

Step-By-Step Instructions

These written instructions are provided here. The Owner's Manual and video are also available on the Internet. http://www.youtube.com/watch?feature=player_detailpage&v=ZmZyR4oX7sM

1. Determine on what type of wall you will be installing your machine - wood, drywall, steel or masonry? Follow appropriate instructions.
2. Determine your personal working height (see below).

Cutting Bed Elevation Chart

Generally speaking, most framers determine the cutting bed height (the height that your media rests on) of their machine as influenced by two factors: employee's work height, and the weight and size of the materials to be placed onto the cutting bed of the Onyx 90. For example if you are tall, then mounting the machine higher may be better for you. If you process a lot of large sized glass, acrylic or other sheet materials, you may find a lower cutting bed height better. Always think of safety when lifting and processing your materials. From the following chart, choose the cutting bed height suited for you and your employees. Once you have determined your cutting bed height, this chart will indicate the measurement of the top hole of the top hanging bracket.

Onyx 90 Media Cutter

Cutting Bed Elevation Chart

33 inches above the floor	93 inches above the floor
32 inches above the floor	92 inches above the floor
31 inches above the floor	91 inches above the floor
30 inches above the floor	90 inches above the floor
29 inches above the floor	89 inches above the floor
28 inches above the floor	88 inches above the floor
27 inches above the floor	87 inches above the floor
26 inches above the floor	86 inches above the floor
25 inches above the floor	85 inches above the floor

Note: If you have an 8' ceiling, the maximum cutting bed height will be 31" from the floor.

Installation on a Wood Wall

It is very helpful to watch the "How To Install" video

http://www.youtube.com/watch?v=ZmZyR4oX7sM&feature=player_detailpage

1. Remove protective polyethylene film from all stainless steel parts.
2. Locate a vertical stud on the wall.
3. Using a level, draw a vertical line 94" in length on the wall to the floor.
4. Drill a 1/8" pilot hole on the line 91" from the floor. (See above chart to determine your personal working height.)
5. Using the top hanging bracket as a template, center the top hole of the top hanging bracket over the drilled hole on the line. Trace two circles for the two lower holes.
6. Remove the bracket/template and drill the two lower 1/8" pilot holes
7. Place the top hanging bracket over the holes and using the screws and washers from the bracket hardware package, mount the top hanging bracket in all three places.
8. Measure 29 1/4" down from the *bottom* of the top hanging bracket and place a mark on the vertical line.
9. Place the *top* of the bottom hanging bracket on that measurement line – the one you just marked at 29 1/4".
10. Using the bottom hanging bracket as a template, center the two holes in the bottom hanging bracket over the vertical line.
11. Trace the two holes with a pencil.
12. Remove the bottom hanging bracket/ template and drill the two 1/8" pilot holes.
13. Place the bottom hanging bracket over the holes and using the screws and washers from the bracket hardware package, mount the bottom hanging bracket to the wall.
14. Check to verify that the top and bottom hanging brackets are in line with each other and plum.

Onyx 90 Media Cutter

Installation on a Masonry Wall

It is very helpful to watch the "How To Install" video

http://www.youtube.com/watch?v=ZmZyR4oX7sM&feature=player_detailpage

1. Use a 1/4" masonry drill bit to drill all holes into the wall.
2. Insert blue plastic anchors into drilled holes in the wall.
3. Follow all other instructions for a wood wall installation.

Mounting the Vertical Axis Extrusion

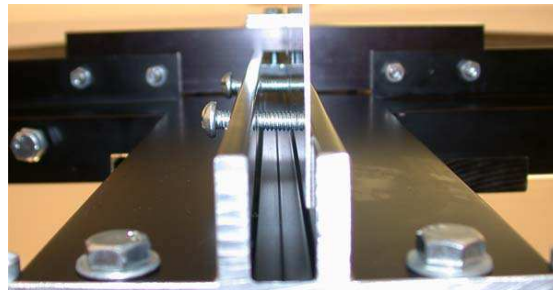

1. Locate the bearing tubes and cart assembly with attached vertical axis assembly. Place it on the top bracket and insert the safety screw and nut. The screw is 1/4-20 X 1 1/2" long. This is very important for safety.
2. Lift and situate the vertical axis extrusion with the bearing tubes and cart assembly so that the flanges on the back of the vertical axis extrusion straddle the top and bottom brackets. See above image.
3. Lightly tighten the five screws on the vertical axis extrusion to the two vertical wall brackets.. There will be a further adjustment later.
4. Locate the left horizontal extrusion – it is marked.
5. Attach the left horizontal extrusion to the left mounting bracket. Note: the left and right horizontal mounting brackets are identical.
6. Place the left horizontal extrusion onto the vertical axis extrusion. Use two 1/4-20 X 2" hex head screws, washers and locking nuts to attach the left horizontal extrusion to the square tube on the vertical axis extrusion.
7. Attach the left stainless steel gusset plate to the left horizontal extrusion and the vertical axis extrusion using the nine (small flat head) #4 x 40 flat head stainless steel screws and nuts. Attach the left horizontal mounting bracket to the wall. Make sure the bracket is perpendicular to the wall.
8. Place the right horizontal extrusion onto the vertical axis extrusion. Use two 1/4-20 X 2" hex head screws, washers and locking nuts to attach the left horizontal extrusion to the square tube on the vertical axis extrusion.
9. Attach the right stainless steel gusset plate to the right horizontal extrusion and the vertical axis extrusion using nine #4 x 40 flat head stainless steel screws and nuts.
10. Attach the right horizontal extrusion wall mounting bracket to the wall. Again, make sure the bracket is perpendicular to the wall.

Onyx 90 Media Cutter

Squaring the Cutting Beds



Important

In order for the machine to work properly, the cutting beds must be in line. Stand along the side of the Onyx 90 and look down the cutting beds where the left and right cutting beds are attached to the vertical axis extrusion. The cutting beds must not be bowed either towards the wall or bowed away from the wall. Everthing must be in line. This next adjustment will ensure that.

1. **Loosen** the four 1/4" x 20 x 2" screws and nuts located on the back of the vertical axis extrusion. The four screws are located in the square tube attached to the vertical axis extrusion. Do not remove the screws - just loosen making sure that the safety screw & nut are in place.
2. Loosen the 5 mounting screws on the vertical axis extrusion and loosen the 4 screws on the horizontal wall brackets.
3. Using a straightedge placed against the front of the left and right horizontal extrusions, push or pull as necessary to straighten and remove any gap between the straight edge and the horizontal extrusions.
4. While maintaining the pushing/pulling action, have an assistant tighten the four screws located in the square tube on the back of the vertical axis extrusion.

Mounting the Media Clamp Assembly

1. Locate the 1/4-20 tapped hole in the top mounting bracket of the bearing-tubes and cart assembly unit.
2. I nsert the 1/4-20 x 2 3/4" screw of the top mat clamp assembly into the tapped hole in the top mounting bracket of the bearing-tubes and cart-assembly unit. Tighten the 1/4-20 x 2 3/4" screw into the hole and jam the nut to secure.
3. Attach the bottom of the media clamp assembly to the T-nut in the left horizontal extrusion using 1/4-20 x 1" screw and lock washer.
4. Adjust the media clamp assembly so that it is the same distance from the vertical axis extrusion at the top and bottom. When the distances are the same, tighten the screw to the T-nut.
5. You have competed the assembly and mounting of your new Onyx 90 Media Cutter.
6. Double check to make sure all screws and nuts are tight.

Onyx 90 Media Cutter

5.0 Cutting Tool Holders

A word about safety – razor blades, plastic cutting tools and glass wheels can all cut you. Be careful when handling them. **ALLWAYS WEAR SAFTY GLASSES.**

Acrylic Cutting Tool Holder (with blue handle)

Plastics up to 1/4" thick can be scored and fractured on your Onyx 90 machine. The plastic cutting tool holder utilizes a double-ended carbide insert to score your plastic media. This carbide insert provides an extremely durable tool, lasting many thousands of cuts. Warning: this carbide insert is very hard and subject to breakage if dropped.

To remove carbide insert,

1. Remove the slotted machine screw located in the center of the insert with a small screwdriver. The carbide insert has two ends. The carbide insert is captured via a machined slot and can not become misaligned.

Glass Cutting Tool Holder (with red handle)

The Onyx 90's glass cutting tool incorporates a six-position turret which contains six solid carbide glass cutting wheels. This turret is numbered 1 through 6, giving you means to keep track of the new and used carbide wheels in the turret.

To change to a new wheel,

1. Loosen the turret retaining screw 1/2 turn and index the turret to the next position.
2. Align the new wheel so the center of the wheel is aligned with the hole mark on the face of the tool holder. It is very important that the apex (highest point) of the glass wheel is the only part of the holder that is in contact with the glass.
3. Tighten the screw.

Attention: If the turret retaining screw is loosened more than 1/2 turn, the carbide wheels may fall off the axles and become lost. Note: when replacing or removing the turret, always place a newspaper or kraft paper before you begin. In case a wheel fall off, it will be easy to locate it.

Important Tip

To achieve the maximum utilization from your carbide glass cutting wheels, the wheels must be kept well oiled. WD-40 is a good lubricant for this purpose. Before each use one should squirt the active wheel with a "shot" of oil. We recommend you use a small plastic container with a well oil-soaked cloth in the plastic container. When the tool is not in use, place the tool in the container with the wheels down against the cloth. This will ensure the maximum life and best results from your carbide glass cutting wheels.

Onyx 90 Media Cutter

Mat Board Cutting Tool Holder (with black handle)

This tool holder is used for cutting mat board, foam board, gator board, sentra, travicel, cardboard as well as many other media.

Changing and Adjusting Blade Depth

Attention: Use caution during this process so that your hand does not come in contact with the razor blade.

Changing the Blade

1. Loosen the 2 screws on the side of the mat board cutting tool holder
2. Discard the old blade safely.
3. Place a new blade in the mat cutting tool holder and tighten the 2 screws.
4. Note there is small set screw to support the back of the blade (small arrow).

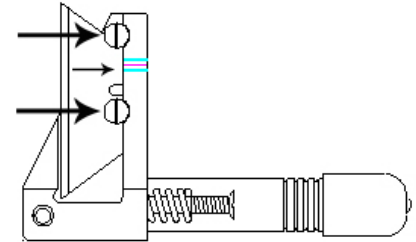

Replacement Blades

The Onyx 90 uses economical blades – Part PPF E-305-2

6.0 Using Your Onyx 90

Changing from one type of tool holder to another

Once you have practiced a few times, we are sure you will agree that the Onyx 90's tool interlock system allows you very fast tool change.

To insert a tool holder into the machine

1. Hold the tool holder by the handle and place the tool onto the grooves in the pivot arm.
2. Notice that on the tool holder there is a locking roll pin located on the bottom front of the tool holders. This locking pin must engage or fit into a matching groove on the pivot arm.
3. Slide the bottom of the tool holder pin into the grooved pivot arm, pull back and down on the spring loaded handle. It will lock in place.

To remove a tool holder from the machine

1. Lift up on the tool handle and remove the tool.

Onyx 90 Media Cutter

Using the Onyx 90 Cutting Tools

Cutting Glass

Attention: Remember to wear eye protection, gloves and protective clothing when handling glass.

1. If you use the media clamp assembly when cutting glass, place on the glass very carefully. Many people don't use the media clamp for cutting glass.
2. Place your glass on the left side of your Onyx 90 machine.
3. Place the glass cutting tool holder on the pivot arm.
4. The larger piece of glass should be on the left side of the cut and the smaller piece of glass should be on the right side of the cut.
5. Use either the right or left measuring scale on the horizontal axis extrusions as necessary.
6. Place your left hand on the glass - apply holding pressure.
7. With your right hand, pull back the handle.
8. Raise the cutting cart to the **top edge** of the glass.
9. Lower the handle and place the glass cutting wheel on the **top edge** of the glass.
You can now take advantage of one of the Onyx 90's best features. You can vary the amount of pressure needed to make an efficient score just by adding more or less pressure. No global machine adjustment is necessary.
10. With one slow, smooth, continuous motion, pull down the cutting cart past the bottom edge of the glass.
11. You have just "scored" the glass. Only score glass *one* time.
12. With your left hand, apply slight pressure on the bottom left edge of the glass near the score. With your right thumb, apply **increasing** pressure on the bottom right edge of glass near the score until the glass separates.
13. The break will occur at the bottom of the score line and run up to the top of the score line. The break chases the score. You may develop your own best technique.

Cutting Mat Board

The Onyx 90 will cut up to 5/8" deep. When cutting materials that deep, a sharp blade and successive cuts in same groove are necessary. The media clamp can not be used on thicknesses greater than 1/4". The use of the media clamp is not mandatory, but on thin media, it will reduce the chance of media buckling. Where it is deemed necessary to have a fine cut edge, a slip sheet under the cut sheet may be desired.

1. Place the mat board cutting tool holder on the pivot arm.
2. Slide the media to be cut onto the left cutting bed of the Onyx 90. Use the right or left measuring scale as necessary.
3. Pull back the handle on the cutting cart until it locks.
You can now take advantage of one of the Onyx 90's best features. You can vary the amount of pressure needed to make efficient cuts just by adding more or less pressure. No global machine adjustment is necessary.
4. With one slow, smooth, continuous motion, pull down the cutting cart past the bottom edge of the media.
5. Release the media clamp.

Onyx 90 Media Cutter

Cutting Plastic

Onyx 90 will cut or “fracture” sensitive plastic up to 1/4” thick. This includes acrylic, polycarbonate, “Plexiglas” etc.

1. Place the plastic cutting tool holder on the pivot arm.
2. Slide the media to be cut onto the left cutting bed of the Onyx 90. Use the right or left measuring scale as necessary.
3. Engage the media clamp by lifting, pushing forward and lowering the clamp into position.
4. Pull back the handle of the cutting cart until it locks.
5. Raise the cutting cart to the upper edge of the fracture sensitive plastic media.
6. Release the handle using the thumb release.

You can now take advantage of one of the Onyx 90’s best features. You can vary the amount of pressure needed to make efficient scores just by adding more or less pressure. No global machine adjustment is necessary.

7. With one slow, smooth, continuous motion, pull down the cutting cart past the bottom edge of the media.
Note: you will hear a gouging sound of the material.
8. Repeat this procedure two or three times, depending upon density of material being scored.
9. To fracture “or crack” the plastic, raise the cutting cart to the top edge of the plastic.
10. Push in on the plastic fracture swing arm handle. At the same time, align the white rollers with the top edge of the fractured sensitive plastic. While apply increasing pressure to the plastic fracture, swing the arm handle until you hear the plastic snap.
11. Continue to hold the pressure on the plastic fracture swing arm handle while pulling down the cutting cart past bottom of the fractured sensitive plastic in one slow, smooth continuous motion.
12. Release the media clamp.
13. Remove the plastic from the Onyx90 and separate the two plastic pieces.



Plastic fracture
swing arm handle

Onyx 90 Media Cutter

Using the Media Clamp

The media clamp requires only one hand to operate. Simply lift up the clamp from its rest position and move it towards the media to be clamped. Gravity will pull the clamp downward and securely lock your work against the stainless steel gusset plate. The clamp is released by lifting up the handle and returning the clamp to the resting position. The media clamp has a rubber blanket that will hold your media very securely. If you cut large size (1/2" thick) material, you may want to purchase the optional horizontal media clamp.

Using the Production Stop

The production stop is used when you are making several consecutive cuts of the same dimension. The production stop can be placed on either the left or right horizontal extrusion.

1. Simply loosen the plastic locking knob and insert the T-nut and production stop into the channel located at the front of either the left or right horizontal extrusion.
2. Rotate the plastic arm until it is against the measuring scale.

7.0 Routine Maintenance

1. Brush all debris from both the left and right cutting beds.
2. Make sure all nuts and bolts remain tight.
3. Do not oil the machine. Use a wax based furniture polish such as

Pledge to clean.



8.0 Adjustments - should they become necessary – but not likely

Squaring the Machine - making the cutting beds perpendicular to the vertical axis extrusion
Your Onyx 90 was squared at the factory and should not require you to make any adjustments.

If for some reason you find it necessary to make this adjustment, here are the steps:

Tools Needed: An assistant
 builder's square
 2 - 7/16" open-end wrench
 2 - 9/16" open-end wrench

Onyx 90 Media Cutter

Step 1

There are two bolts each on the right and left horizontal extrusion that prevent the cutting beds from moving if someone puts a heavy weight on the ends of the cutting beds - safety feature.

Loosen the jam nuts and bolts before making any adjustments to either the left or the right cutting beds.

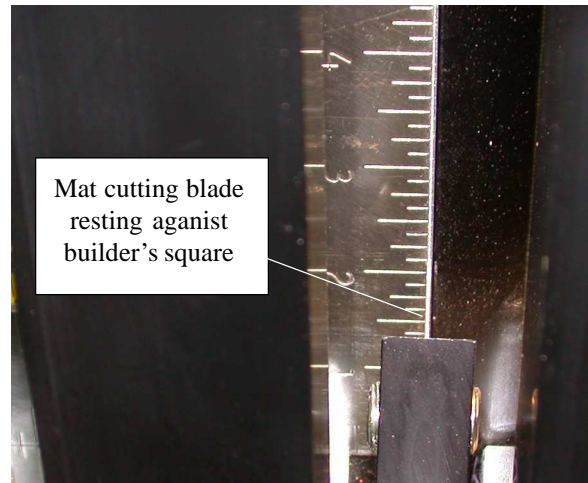
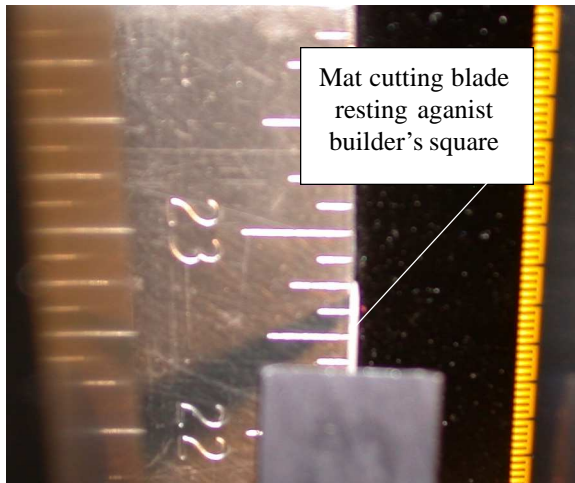

Step 2 - Squaring the Left Cutting Bed

1. Lay the builder's square on the left cutting bed.
2. Put the mat cutting tool in the tool holder. The horizontal portion of the builder's square should be resting on the left cutting bed. The vertical portion of the builder's square should be resting - just touching the mat cutting razor blade. Without moving the builder's square, raise the cutting cart to the top of the vertical portion of the builder's square. The distance from the blade to the builder's square must be the same at the top and bottom throughout the cutting cart's travel.
3. If there is a gap at the *top* of the builder's square/blade intersection, then you must loosen the jam nut on the left side of the left horizontal extrusion. Tighten the 3/8" bolt slightly until the gap disappears. Tighten the jam nut.
4. If there is a gap at the *bottom* of the builder's square/blade intersection, then you must square the left cutting bed the other direction. Loosen the jam nut on the left side of the left horizontal extrusion. You must loosen the 3/8" bolt slightly. This will change the gap. The gap must be the same at the top and bottom of the builder's square throughout the cutting cart's travel. Recheck
5. Once the gap is the same, tighten the jam nut. You have completed squaring the left horizontal cutting bed.

Step 3 - Squaring the Right Cutting Bed

1. Place the builder's square on the left cutting bed and slide the builder's square over to the right cutting bed. There should be no gap under the builder's square on the right cutting bed.
2. If there is a gap *under* the builder's square on the right cutting bed, loosen the two jam nuts under the right horizontal extrusion. Adjust the two 3/8" bolts to make the surface of the right cutting bed flush with the bottom of the builder's square. The builder's square should slide from left-to-right and right-to-left without hitting either cutting beds.

Onyx 90 Media Cutter

3. If the builder's square hits the left or right cutting bed, you will need to adjust the elevation of the innermost bolt on the right cutting bed. Adjust the 3/8" bolt as needed so that the builder's square will travel from left-to-right and right-to-left without hitting either cutting bed.
4. Tighten both the right cutting bed jam nuts. Recheck.

Setp 4 - Finish Swuaring the Cutting Beds

1. Tighten the 1/4 x 20 screws.
2. Bring the jam nuts up to the bottom of the horizontal extrusion and lightly tighten the jam nuts.

Calibration of the Measuring Tape Scales

The horizontal and vertical measuring tape scales have been set at the factory. We have secured the measuring tape scales using a small screw and nut applied at the outside ends of the measuring tape scales. If for some reason you find it necessary to make this adjustment, here are the steps.

1. Position the measuring tape scale where you feel it should be by sliding it in the extrusion
2. Once in position, re-tighten the screw and nut.



Global Adjustment of the Cutting Spring Pressure

This adjustment has been set at the factory. If for some reason you find it necessary to make this adjustment, here are the steps:

1. Remove all cutting tool holders from the cart.
2. The spring tension adjustment nut is located between the bearing tubes on the very bottom of the cart. This adjustment is best done if the bottom of the cutting cart is elevated. You should have an assistant securely hold the cart at that elevation. Do not try to hold it and adjust by yourself.
3. Using a 7/16" nut driver or deep-well socket, reach behind the cart from the right hand side and slide the tool onto the spring tension adjustment nut. If more tension is desired, tighten the spring tension adjustment nut. If less tension is desired, loosen the spring tension adjustment nut. This nut has an internal nylon locking ring to keep it from moving.
4. Once you move it, the nut will stay in that position until you move it again.
5. Insert the glass tool into the cutting cart and try the new pressure. Adjust as required.

Onyx 90 Media Cutter

Adjustment for Depth of Cut

This adjustment has been set at the factory. If for some reason you find it necessary to make this adjustment, here are the steps:

1. Look at the handle located on the cutting cart. Notice a lower handle retaining screw and an upper handle retaining screw. These two screws are counter-bored into the handle and attach the handle to the cutting cart. Just above the upper handle retaining screw, you will see a third combo head screw or allen set screw. This third screw is the “adjustment locking screw.”
2. Loosen the adjustment locking screw until you can insert a large phillips head screwdriver into the slot of the upper handle retaining screw.
3. Insert the glass cutting tool onto tool pivot arm.
4. Release the handle with the thumb release and allow the glass cutting tool to bottom.
5. With the handle in the released or bottomed position, rotate the upper handle retaining screw clockwise to *decrease* the depth.



6. Rotate the upper handle retaining screw counter clockwise to *increase* the depth. After you have made the adjustment to the cutting depth, be sure to push the handle in so that it is resting on the new adjusted stop distance.

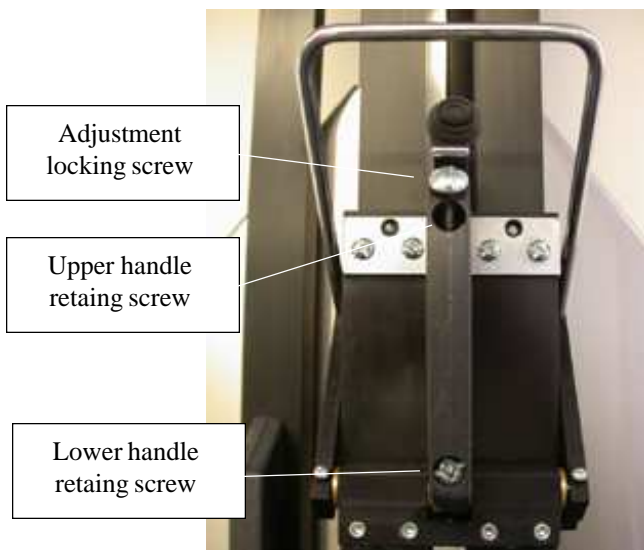

New version uses allen head set screw.

7. Recheck and tighten the adjustment locking screw.



Onyx 90 Media Cutter

9.0 Troubleshooting

When cutting glass, the glass cutter jumps or skips.

Causes: Dirty glass

Clean glass

Worn glass wheel

Rotate to new wheel

Too little pressure

Adjust by applying slight pressure with hand

Oil the active wheel

Shards of glass impairing proper rotation of glass wheel

Blast with areosole such as WD40

Important Tip

To achieve the maximum utilization from your carbide glass cutting wheels, the wheels must be kept well oiled. WD-40 is a good lubricant for this purpose. Before each use one should squirt the active wheel with a "shot" of oil. We recommend you use a small plastic container with a well oil-soaked cloth in the plastic container. When the tool is not in use, place the tool in the container with the wheels down against the cloth. This will ensure the maximum life and best results from your carbide glass cutting wheels.

When cutting glass, chipping or flaking occurs.

Cause: Too much pressure

Oil the active wheel. *You may be applying too much pressure on the handle. Pull back on the handle during cut.*

Too much pressure will shorten wheel life.

Never score twice.

When cutting plastic, it skips and/or chatters.

Causes: Scoring too fast

Slow down the stroke speed

Scoring tool broken

Rotate cutter if you have not done so previously

Too much pressure

Reduce pressure slightly on handle

Not using media clamp

Use media clamp

Onyx 90 Media Cutter

When cutting mat board, the mat board buckles.

Causes: Mat board not clamped
Use media clamp

Blade too dull
Change to new blade

The cut edge of mat board is frayed.

Causes: Dull mat cutting blade
Change to new blade

No slip sheet under media being cut
Use slip sheet

When I make my cuts, the dimensions are incorrect.,

Cause: The measuring scale is off
Recalibrate the measuring scale

The cut edge is not square - not a 90 degree cut.

Causes: Debris between the media and cutting bed
Remove debris

Cutting bed is not perpendicular to vertical extrusion.
Square the cutting bed -Not likely-

You are very important to us. Our success depends on your satisfaction. If you are having any problems or have any comments, please call us at 828-707-5848.

Onyx 90 Media Cutter

Onyx 90 Product Registration Card

Registering your Onyx 90 media cutter is essential to ensure that you validate your warranty and receive all the benefits of product ownership.

Date of Purchase _____
First Name _____
Last Name _____
Street Address _____
Street Address _____
City, State, Zip _____
Email Address _____
Phone Number _____
Serial Number _____

Mail to Professional Picture Frame Equipment
1237 Shipp Street
Hendersonville, NC 28791



Fastest tool change in the industry
Anodized aluminum and stainless steel
Oil impregnated bronze bushings
Ultra high molecular weight polyethylene bearings
Production stop included
Cutting depth 5/8 inches
Built-in mat board and acrylic clamp

Cuts mat board, gator board, glass and acrylic
Built to last a life-time
FedEx/UPS shippable
Five year warranty
Stainless steel wall mounting brackets
Carbide plastic cutter
Made in the USA